

Managing Noise and Preventing Hearing Loss at Work

Code of Practice

December 2012
CPI 18

This code of practice has been approved by the Tasmanian Minister for Workplace Relations under section 274 of the *Work Health and Safety Act 2012* and commences on 1 January 2013.

This code of practice is based on a national model code of practice developed by Safe Work Australia as part of the harmonisation of work health and safety laws under the Council of Australian Governments' *Inter-governmental Agreement for Regulatory and Operational Reform in Occupational Health and Safety*.

Safe Work Australia is an Australian Government statutory agency established in 2009. Safe Work Australia consists of representatives of the Commonwealth, state and territory governments, the Australian Council of Trade Unions, the Australian Chamber of Commerce and Industry and the Australian Industry Group.

Safe Work Australia works with the Commonwealth, state and territory governments to improve work health and safety and workers' compensation arrangements. Safe Work Australia is a national policy body, not a regulator of work health and safety. The Commonwealth, states and territories have responsibility for regulating and enforcing work health and safety laws in their jurisdiction.



Creative Commons

Except for the Safe Work Australia logo, this copyright work is licensed under a Creative Commons Attribution-Noncommercial 3.0 Australia licence.

[Creative Commons Attribution-Noncommercial 3.0 Australia licence information](#)

In essence, you are free to copy, communicate and adapt the work for non commercial purposes, as long as you attribute the work to Safe Work Australia and abide by the other licence terms.

FOREWORD	4
1. INTRODUCTION	5
1.1 Who has health and safety duties in relation to noise?	5
1.2 The meaning of key terms	5
1.3 What is required to <i>manage the risks</i> of hearing loss?	6
2. NOISE AND ITS EFFECT ON HEALTH AND SAFETY	8
2.1 How does hearing loss occur?	8
2.2 How much noise is too much?	8
2.3 Other effects of noise	10
3. HOW TO IDENTIFY THE HAZARDS	11
3.1 How to find noise hazards	11
3.2 What happens next?	12
4. HOW TO ASSESS THE RISKS	13
4.1 When should a risk assessment be conducted?	13
4.2 Who can do a noise assessment?	13
4.3 How should a noise assessment be done?	13
4.4 What information should be included in a noise assessment report?	14
5. HOW TO CONTROL THE RISKS	15
5.1 The hierarchy of risk control	15
5.2 Substituting plant or processes to reduce noise	15
5.3 Using engineering controls	16
5.4 Isolating the source of noise	16
5.5 Using administrative controls	17
5.6 Using personal hearing protectors	17
5.7 Audiometric testing	19
5.8 Information, training and instruction	20
5.9 Implementing and maintaining control measures	21
6. HOW TO REVIEW CONTROL MEASURES	22
7. ROLE OF DESIGNERS, MANUFACTURERS, SUPPLIERS AND INSTALLERS ...	23
7.1 Designers	23
7.2 Manufacturers	25
7.3 Suppliers and importers	25
7.4 Installers	26
7.5 What information should be provided to potential users?	26
APPENDIX A – OTHER CAUSES OF HEARING LOSS IN THE WORKPLACE	28
APPENDIX B – NOISE HAZARD IDENTIFICATION CHECKLIST	33
APPENDIX C – READY RECKONER	34
APPENDIX D – CONTENTS OF A NOISE ASSESSMENT REPORT	39
APPENDIX E – ENGINEERING CONTROL MEASURES	40

FOREWORD

This Code of Practice for managing noise and preventing hearing loss at work is an approved code of practice under section 274 of the *Work Health and Safety Act* (the WHS Act).

An approved code of practice is a practical guide to achieving the standards of health, safety and welfare required under the WHS Act and the Work Health and Safety Regulations (the WHS Regulations).

A code of practice applies to anyone who has a duty of care in the circumstances described in the code. In most cases, following an approved code of practice would achieve compliance with the health and safety duties in the WHS Act, in relation to the subject matter of the code. Like regulations, codes of practice deal with particular issues and do not cover all hazards or risks that may arise. The health and safety duties require duty holders to consider all risks associated with work, not only those for which regulations and codes of practice exist.

Codes of practice are admissible in court proceedings under the WHS Act and Regulations. Courts may regard a code of practice as evidence of what is known about a hazard, risk or control and may rely on the code in determining what is reasonably practicable in the circumstances to which the code relates.

Compliance with the WHS Act and Regulations may be achieved by following another method, such as a technical or an industry standard, if it provides an equivalent or higher standard of work health and safety than the code.

An inspector may refer to an approved code of practice when issuing an improvement or prohibition notice.

This Code of Practice has been developed by Safe Work Australia as a model code of practice under the Council of Australian Governments' *Inter-Governmental Agreement for Regulatory and Operational Reform in Occupational Health and Safety* for adoption by the Commonwealth, state and territory governments.

A draft of this Code of Practice was released for public consultation on 7 December 2010 and was endorsed by the Workplace Relations Ministers' Council on 10 August 2011.

SCOPE AND APPLICATION

This Code of Practice applies to all types of work and all workplaces covered by the WHS Act where there is the potential for exposure to noise that can contribute to hearing loss. It provides practical guidance to persons conducting a business or undertaking on how noise affects hearing, how to identify and assess exposure to noise and how to control health and safety risks arising from hazardous noise.

Although the WHS Regulations for noise are limited to managing the risks of hearing loss, the duties in the WHS Act extend to all health and safety risks arising from the conduct of a business or undertaking and therefore this Code also includes information about other agents that may contribute to hearing loss in Appendix A.

How to use this Code of Practice

In providing guidance, the word 'should' is used in this Code to indicate a recommended course of action, while 'may' is used to indicate an optional course of action.

This Code also includes various references to sections of the WHS Act and Regulations which set out the legal requirements. These references are not exhaustive. The words 'must', 'requires' or 'mandatory' indicate that a legal requirement exists and must be complied with.

1. INTRODUCTION

Hazardous noise can destroy the ability to hear clearly and can also make it more difficult to hear sounds necessary for working safely, such as instructions or warning signals.

Managing the risks related to noise will assist in:

- protecting workers from hearing loss and disabling tinnitus (ringing in the ears or head)
- improving the conditions for communication and hearing warning sounds
- creating a less stressful and more productive work environment.

1.1 Who has health and safety duties in relation to noise?

A **person conducting a business or undertaking** has the primary duty under the WHS Act to ensure, so far as is reasonably practicable, that workers and other persons are not exposed to health and safety risks arising from the business or undertaking.

A person conducting a business or undertaking has more specific obligations under the WHS Regulations to manage the risks of hearing loss associated with noise at the workplace, including:

- ensuring that the noise a worker is exposed to at the workplace does not exceed the exposure standard for noise
- providing audiometric testing to a worker who is frequently required to use personal hearing protectors to protect the worker from hearing loss associated with noise that exceeds the exposure standard.

Designers, manufacturers, suppliers, importers and installers of plant or structures that could be used for work must ensure, so far as is reasonably practicable, that the plant or structure is without risks to health and safety. Designers and manufacturers of plant must ensure the plant is designed and manufactured so that its noise emission is as low as reasonably practicable.

Designers, manufacturers, suppliers and importers must also provide information about the noise emission values of the plant and any conditions necessary for minimising the risk of hearing loss and other harm (see Chapter 7 of this Code).

Officers, such as company directors, have a duty to exercise due diligence to ensure that the business or undertaking complies with the WHS Act and Regulations. This includes taking reasonable steps to ensure that the business or undertaking has and uses appropriate resources and processes to eliminate or minimise risks that arise from noise.

Workers have a duty to take reasonable care for their own health and safety and that they do not adversely affect the health and safety of other persons. Workers must comply with any reasonable instruction and cooperate with any reasonable policy or procedure relating to health and safety at the workplace. For example, if personal hearing protectors are provided by the person conducting the business or undertaking, the worker must use them in accordance with the information, instruction and training provided on their use.

1.2 The meaning of key terms

Decibel (dB) is the unit for measuring sound levels.

Exposure standard for noise is defined in the WHS Regulations as an $L_{Aeq,8h}$ of 85 dB(A) or an $L_{C,peak}$ of 140 dB(C). There are two parts to the exposure standard for noise because noise can either cause gradual hearing loss over a period of time or be so loud that it causes immediate hearing loss.

L_{Aeq,8h} means the eight hour equivalent continuous A-weighted sound pressure level in decibels, referenced to 20 micropascals, determined in accordance with AS/NZS 1269.1. This is related to the total amount of noise energy a person is exposed to in the course of their working day. It takes account of both the noise level and the length of time the person is exposed to it. An unacceptable risk of hearing loss occurs at L_{Aeq,8h} values above 85 dB(A).

L_{C,peak} means the C-weighted peak sound pressure level in decibels, referenced to 20 micropascals, determined in accordance with AS/NZS 1269.1. It usually relates to loud, sudden noises such as a gunshot or hammering. L_{C,peak} values above 140 dB(C) can cause immediate damage to hearing.

Hazardous noise in relation to hearing loss means noise that exceeds the exposure standard for noise in the workplace.

Risk control means taking action to first eliminate health and safety risks so far as is reasonably practicable, and if that is not possible, minimising the risks so far as is reasonably practicable. Eliminating a hazard will also eliminate any risks associated with that hazard.

1.3 What is required to *manage the risks of hearing loss*?

Regulation 34-38: In order to manage risk under the WHS Regulations, a duty holder must:

- a) identify reasonably foreseeable hazards that could give rise to the risk
- b) eliminate the risk so far as is reasonably practicable
- c) if it is not reasonably practicable to eliminate the risk – minimise the risk so far as is reasonably practicable by implementing control measures in accordance with the hierarchy of control
- d) maintain the implemented control measure so that it remains effective
- d) review, and if necessary revise, risk control measures so as to maintain, so far as is reasonably practicable, a work environment that is without risks to health and safety.

This Code provides guidance on how to manage the risks of hearing loss associated with noise by following a systematic process that involves:

- identifying sources of noise that may cause or contribute to hearing loss,
- if necessary, assessing the risks associated with these hazards,
- implementing risk control measures
- reviewing risk control measures.

Guidance on the general risk management process is available in the *Code of Practice: How to Manage Work Health and Safety Risks*.

Consulting your workers

Consultation involves sharing of information, giving workers a reasonable opportunity to express views and taking those views into account before making decisions on health and safety matters.

Section 47: The WHS Act requires that you consult, so far as is reasonably practicable, with workers who carry out work for you who are (or are likely to be) directly affected by a work health and safety matter.

Section 48: If the workers are represented by a health and safety representative, the consultation must involve that representative.

Consultation with workers and their health and safety representatives is required at each step of the risk management process. By drawing on the experience, knowledge and ideas of your workers you are more likely to identify all hazards and choose effective control measures.

You must also consult your workers when proposing to make any changes that may affect their health and safety, for example when planning to buy new machinery or equipment.

Health and safety representatives must have access to relevant information such as noise exposure data and potential control options. If you have a health and safety committee, you should engage the committee in the process as well.

Consulting, co-operating and co-ordinating activities with other duty holders

Section 46: The WHS Act requires that you consult, co-operate and co-ordinate activities with all other persons who have a work health or safety duty in relation to the same matter, so far as is reasonably practicable.

Sometimes you may share responsibility for a health and safety matter with other business operators who are involved in the same activities or who share the same workplace. In these situations, you should exchange information to find out who is doing what and work together in a co-operative and co-ordinated way so that all risks are eliminated or minimised as far as reasonably practicable.

For example, if you own or manage an on-hire business and your workers work at other workplaces then you must consult the host business so far as is reasonably practicable to determine if your workers could be exposed to hazardous noise and agree on what you each will do to control any associated risks.

Further guidance is available in the *Code of Practice: Work Health and Safety Consultation, Co-operation and Co-ordination*.

2. NOISE AND ITS EFFECT ON HEALTH AND SAFETY

2.1 How does hearing loss occur?

Hazardous noise affects the functioning of the inner ear, which may cause temporary hearing loss. After a period of time away from noise, hearing may be restored. With further exposure to hazardous noise, the ear will gradually lose its ability to recover and the hearing loss will become permanent.

Permanent hearing loss can also occur suddenly if a person is exposed to very loud impact or explosive sounds. This type of damage is known as acoustic trauma.

Permanent hearing loss results from the destruction of hair cells in the inner ear. These cells cannot be replaced or repaired by any presently known medical treatments or technology.

Usually, hazardous noise first affects the ability to hear high-frequency (high-pitched) sounds. This means that even though a person can still hear some sounds, conversation will start to sound 'muffled' and a person may find it difficult to understand what is being said.

Communication difficulties occur especially when there are competing background noises. Modern hearing aids may improve the ability to hear speech but they are unable to completely restore the clarity of the full hearing function.

Workers exposed to hazardous noise may also experience tinnitus, which could become permanent. When severe, it may disrupt sleep, reduce concentration, make people extremely irritable and lead to depression.

The degree of hearing loss that occurs is dependent on how loud the noise is, how long someone is exposed to it and, to some extent, individual susceptibility. The frequency or pitch can also have some effect on hearing loss, since high-pitched sounds are more damaging than low-pitched ones.

Exposure to a number of common industrial chemicals and some medications can also cause hearing loss or exacerbate the effects of noise on hearing. These substances are called ototoxic substances.

Ototoxic substances absorbed into the bloodstream may damage the cochlea in the inner ear and/or the auditory pathways to the brain, leading to hearing loss and tinnitus. Hearing loss is more likely if exposure is to a combination of substances or a combination of the substance and noise.

There is also some evidence that exposure to hand transmitted vibrations can exacerbate the effects of noise on hearing.

Further information on these other causes of hearing loss is provided in Appendix A.

2.2 How much noise is too much?

Whether the exposure standard of 85 dB(A) averaged over eight hours is exceeded depends on the level of noise involved and how long workers are exposed to it.

Peak noise levels greater than 140 dB(C) usually occur with impact or explosive noise such as sledge-hammering or a gun shot. Any exposure above this peak can create almost instant damage to hearing.

Decibels are not like normal numbers. They can't be added or subtracted in the normal way. The decibel scale is logarithmic. On this scale, an increase of 3 dB therefore represents a doubling or twice as much sound energy. This means that the length of time a worker could be exposed to the noise is reduced by half for every 3 dB increase in noise level if the same noise energy is to be received.

Table 1 below demonstrates the length of time a person without hearing protectors can be exposed before the standard is exceeded.

Table 1: Equivalent Noise Exposures	
L_{Aeq,8h} = 85 dB(A)	
Noise Level dB(A)	Exposure Time
80	16 hours ¹
82	12hours ¹
85	8 hours
88	4 hours
91	2 hours
94	1 hour
97	30 minutes
100	15 minutes
103	7.5 minutes
106	3.8 minutes
109	1.9 minutes
112	57 seconds
115	28.8 seconds
118	14.4 seconds
121	7.2 seconds
124	3.6 seconds
127	1.8 seconds
130	0.9 seconds

Essentially, a worker who is exposed to 85 dB(A) for 8 hours receives the same noise energy as someone exposed to 88 dB(A) for 4 hours, with the balance of the day in a very quiet environment. In both cases the exposure standard is not being exceeded. However, being exposed to 88 dB(A) for more than 4 hours would mean that the standard is exceeded. Similarly, if a worker is using a machine that generates 121 dB(A) then the exposure standard would be exceeded after only 7.2 seconds.

There is a big range in different people’s susceptibility to hearing loss from noise. Research shows that 8-hour average daily noise exposure levels below 75 dB(A) or instantaneous peak noise levels below 130 dB(C) are unlikely to cause hearing loss. With progressively increasing levels, the risk becomes greater.

The WHS Regulations set the exposure standard for noise at an L_{Aeq,8h} of 85 dB(A) and a peak noise level at 140 dB(C), which protects most but not all people. Therefore, workplace noise should be kept lower than the exposure standard for noise if reasonably practicable.

¹ The adjustment factor for extended workshifts shown in Table 3 of this Code is taken into account.

2.3 Other effects of noise

Noise at levels that do not damage hearing can have other adverse health effects. This can arise when noise chronically interferes with concentration and communication. Persistent noise stress can increase the risk of fatigue and cardiovascular disorders including high blood pressure and heart disease.

Although safe levels to guard against these effects have not yet been fully determined, as a guide, the risk of adverse health effects can be minimised by keeping noise levels below:

- 50 dB(A) where work is being carried out that requires high concentration or effortless conversation
- 70 dB(A) where more routine work is being carried out that requires speed or attentiveness or where it is important to carry on conversations.

These levels include the noise from other work being carried out within the workplace.

To work safely, workers must be able to hear warning signals above any other noise (ambient noise) at the workplace. For reversing alarms on mobile plant, the guidance in ISO:9533: 2010 *Earth-moving machinery – Machine-mounted audible travel alarms and forward horns – Test methods and performance criteria* should be followed. This requires the noise level of the alarm at potential reception points to be at least as high as the noise from the engine under high idle.

For other situations, the levels needed are higher – at least 65 dB(A) and more than 15 dB(A) greater than the ambient noise level at any position in the signal reception area. More detailed guidance on assessing the audibility of warning signals can be found in ISO 7731:2003 *Ergonomics – Danger signals for public and work areas – Auditory danger signals*.

3. HOW TO IDENTIFY THE HAZARDS

The potential for noise to be hazardous is not always obvious. Hazard identification is a way of finding out which work activities have the potential to contribute to hearing loss or other harm caused by noise.

Exposure to noise is cumulative and a worker may perform a number of noisy work activities over time which, in combination, may expose the worker to hazardous noise.

3.1 How to find noise hazards

You may not need specialist skills to identify sources of hazardous noise, but you must undertake the process in consultation with your workers and their health and safety representatives. As a guide, if you need to raise your voice to communicate with someone about one metre away, the noise is likely to be hazardous to hearing.

A checklist is provided in Appendix B to help you further with this process.

Inspect the workplace

Regularly walking around the workplace, talking to workers and observing how things are done can help you identify noise hazards. Find out where noise is coming from and which tasks or processes produce noise. Take immediate action to control noise where this is possible, for example fix loose panels that are vibrating and rattling during machine operation.

Review available information

Information regarding noise levels from the manufacturers or suppliers of plant and equipment used at the workplace should be obtained.

Information and advice about hazards and risks relevant to particular industries and work activities is also available from regulators, industry associations, unions, technical specialists and safety consultants.

You should check whether any workers' compensation claims have been made for hearing loss and if any hearing loss or tinnitus has been found during repeat audiometric testing. If a worker's hearing has been affected and has been attributed to a particular task, then a hazard may exist that could affect other workers.

Table 2 below lists common noise sources and their typical sound levels which can be used to compare whether noise in the workplace sounds as loud as or louder than 85 dB(A).

Table 2: Common noise sources and their typical sound levels

Typical sound level in dB	Sound source
140	Jet engine at 30m
130	Rivet hammer (pain can be felt at this threshold)
120	Rock drill
110	Chain saw
100	Sheet-metal workshop
90	Lawn-mower
85	Front-end loader
80	Kerbside Heavy traffic
	Lathe
70	Loud conversation
60	Normal conversation
40	Quiet radio music
30	Whispering
0	Hearing threshold

3.2 What happens next?

In consultation with your workers and health and safety representatives, make a list of all noisy activities that may pose a risk to the health and safety of persons at the workplace. If you have answered 'yes' to any of the questions in Appendix B, it is likely that your workers are being exposed to hazardous noise. If you are unsure about the level of exposure or how to eliminate or minimise the risks effectively, you should take the next step to assess the risks of hearing loss.

4. HOW TO ASSESS THE RISKS

4.1 When should a risk assessment be conducted?

If you have identified any noisy activities that may expose your workers or other people at your workplace to hazardous noise then, unless you can reduce the exposures to below the standard immediately, you should assess the risks by carrying out a noise assessment.

A noise assessment will help you:

- identify which workers are at risk of hearing loss
- determine what noise sources and processes are causing that risk
- identify if and what kind of noise control measures could be implemented
- check the effectiveness of existing control measures.

A noise assessment may not always need measurement. For example, if only one activity at the workplace – the use of a single machine – involves noise above 85 dB(A) and the manufacturer has provided information about the machine's noise levels when it is operated in particular ways, then a sufficient assessment can be made without measurement. More complex situations may require measurement to accurately determine a worker's exposure to noise, such as workplaces with variable noise levels over a shift and jobs where workers move in and out of noisy areas.

4.2 Who can do a noise assessment?

A noise assessment should be done by a competent person in accordance with the procedures in AS/NZS 1269.1 *Measurement and assessment of noise immission and exposure*. The more complex the situation, the more knowledgeable and experienced the person needs to be.

A competent person is one who has accurately calibrated noise measuring instruments and, through training and experience:

- understands what is required by the WHS Regulations for noise
- knows how to check the performance of the instruments
- knows how to take the measurements properly
- can interpret the results of the noise measurements.

4.3 How should a noise assessment be done?

The way a noise assessment is done will depend upon:

- the type of workplace
- the number of persons potentially at risk from exposure to hazardous noise
- the information already available on noise at the workplace.

A noise assessment should be done during a typical working shift and should determine:

- the noise levels produced during various tasks carried out during the shift
- how long your workers are exposed to noise during each of these tasks.

An assessment should take into account:

- plant, equipment and other sources of noise in operation at the workplace
- how work activities are carried out
- the length of the shift
- environmental factors (e.g. types of walls, surfaces, layout of work stations).

This means that adequate information about the tasks and their frequency is needed, so consultation with workers and their supervisors is essential.

Noise measurements should be taken at 0.1 to 0.2 metres from the worker's ear canal entrance over a period of time that is representative of the noise produced during the tasks.

In most situations the use of a hand-held integrating sound level meter will produce the most useful information for choosing appropriate noise control measures. In situations where workers are highly mobile or access for the person taking the measurement is difficult or unsafe, it may be more appropriate to use personal sound exposure meters (dose meters).

Noise measurements should include the combined noise levels of all the tools, machines and processes present as well as the background noise from ventilation systems, cooling compressors, circulation pumps, etc. To identify which noise sources contribute most to workers' exposures, the noise from each source or work activity should also be measured separately.

The Ready Reckoner in Appendix C may be used to work out the total $L_{Aeq,8h}$ for combinations of noise levels and exposure duration for each work activity and the relative importance of each.

If a group of workers is exposed to identical sources of noise and their exposure is likely to be the same, then you do not need a separate assessment for each worker. A representative assessment can be done for one or more of the workers.

Extended work shifts

Shift durations of 10 hours or longer involve a degree of risk greater than that indicated by the 8 hour measurement $L_{Aeq,8h}$. This increase in risk arises because of the additional damaging effect of continuous exposure to noise after 10 hours. The risk may be further increased if there is reduced recovery time between successive shifts.

If workers work shifts of 10 hours or more, the adjustment factor for extended shifts as set out in AS/NZS 1269.1 (see Table 3) should be added to the measured $L_{Aeq,8h}$ before comparing it with the 85 dB(A) exposure standard for noise.

Table 3: Adjustments to $L_{Aeq,8h}$ for extended work shifts

Shift length	Adjustment added to measured $L_{Aeq,8h}$ dB(A)
10 hrs or more to less than 14 hrs	+ 1
14 hrs or more to less than 20 hrs	+ 2
20 hrs or more	+ 3

For example, if a worker works 12-hour shifts and the typical $L_{Aeq,8h}$ has been determined to be 93 dB(A), an additional one decibel is added to give an adjusted $L_{Aeq,8h}$ of 94 dB(A). Hence the worker's $L_{Aeq,8h}$ exceeds the exposure standard for noise by 9 dB(A). For a fully worked example see Appendix C.

If workers work more than five days per week, the weekly averaging procedure of AS/NZS 1269.1 should be used.

4.4 What information should be included in a noise assessment report?

Noise assessment reports should show that the assessment was done properly and that all factors were taken into account. An assessment report should contain all the information shown in Appendix D. Noise assessment reports should be used to select appropriate control measures. The main findings should be included in training for all workers. The reports should be made available to managers, health and safety representatives and regulators.

5. HOW TO CONTROL THE RISKS

The most important step in the risk management process involves eliminating the risks, or if that is not reasonably practicable, minimising the risks so far as is reasonably practicable.

5.1 The hierarchy of risk control

The WHS Regulations require duty holders to work through a hierarchy of control to choose the control measure that most effectively eliminates or minimises the risk in the circumstances. The hierarchy ranks the ways of controlling the risk of hearing loss from noise from the highest level of protection and reliability to the lowest so that the most effective controls are considered first.

Effective risk control may involve a single control measure or a combination of two or more different controls.

Eliminate the risk

The most effective control measure is to eliminate the source of noise completely, for example by ceasing to use a noisy machine, changing the way work is carried out so hazardous noise is not produced or by not introducing the hazard into the workplace.

Minimise the risk

If it is not reasonably practicable to eliminate the source of noise, you must minimise the risk associated with hearing loss so far as is reasonably practicable. This includes ensuring that the noise does not exceed the exposure standard by choosing one or more of the following measures:

- substitute the hazard with plant or processes that are quieter
- modify plant and processes to reduce the noise using engineering controls
- isolate the source of noise from people by using distance, barriers, enclosures and sound-absorbing surfaces.

If there is a remaining risk, it must be minimised so far as is reasonably practicable by implementing administrative controls, and if a risk still remains, then suitable personal protective equipment must be provided and used. These two types of control measures, when used on their own, tend to be least effective in minimising risks because they rely on human behaviour and supervision.

5.2 Substituting plant or processes to reduce noise

Buy 'quiet'

One of the most cost-effective and long-term ways of reducing noise at work is to introduce a purchasing and hiring policy to choose the quietest plant for the job. This can be done by obtaining information on noise emission (for example, data on sound power level or sound pressure level at the operator position) from the manufacturer, importer or supplier of plant and comparing it to determine the quietest plant.

Ask the suppliers about the likely noise emission under the particular conditions in which you will operate the machinery, as well as under standard test conditions. If you ask the same question to all suppliers you can compare information. Sound power level data will only ever be a guide as many factors affect the actual noise levels experienced by your workers, but it will help you buy quieter machines.

You should purchase or hire only from suppliers who can demonstrate a low noise design, with noise control as a standard part of the machine, not as an optional extra.

Change the way you do the job

A different way of doing the job may provide the same result with a lot less noise. For example, bending metal in a vice or a press is quieter than hammering it into shape, welding is generally quieter than riveting, gluing is quieter than hammering in nails, clipping is quieter than stapling, and lowering materials in a controlled manner is quieter than dropping them on hard surfaces.

5.3 Using engineering controls

A good understanding of the operation of the plant or process is necessary when considering ways of minimising noise at its source.

Examples of engineering control measures include:

- eliminating impacts between hard objects or surfaces
- minimising the drop height of objects or the angle that they fall onto hard surfaces
- using absorbent lining on surfaces to cushion the fall or impact of objects
- fitting exhaust mufflers on internal combustion engines
- fitting silencers to compressed air exhausts and blowing nozzles
- isolating a vibrating noise source to separate it from the surface on which it is mounted using rubber mounts and flexible connections
- ensuring gears mesh together better
- fixing damping materials (such as rubber) or stiffening to panels to reduce vibration
- fitting sound-absorbing materials to hard reflective surfaces
- turning down volume controls
- changing fan speeds or the speeds of particular components
- changing the material the equipment or its parts are made of (change metal components to plastic components).

Further information on using engineering controls is at Appendix E.

5.4 Isolating the source of noise

Examples of isolating the source of noise from workers include:

- building enclosures or sound proof covers around noise sources
- using barriers or screens to block the direct path of sound
- locating noise sources further away from workers (see Figure 1)
- using remote controls to operate noisy plant from a distance.

Figure 1: Sound spreading in an open space away from reflecting surfaces and measured at a certain distance from the source is reduced by about 6 dB for each doubling of that distance. Sound is reduced less when spreading inside an enclosed space.

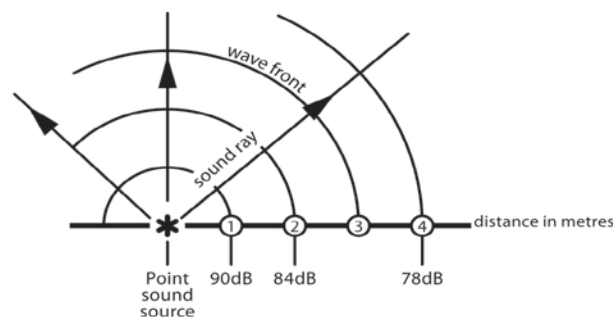

If a small sound source produces a sound level of 90 dB(A) at a distance of 1 metre, the sound level at 2 metres distance is 84 dB(A), and at 4 metres is 78 dB(A), etc.

Maintenance

Regular maintenance of plant and equipment is essential as it will deteriorate with age and can become noisier. Check for changes in noise levels – badly worn bearings and gears, poor lubrication, blunt blades, loose parts, unbalanced rotating parts and steam or air leaks all create noise that can be reduced with good maintenance. Engineering controls such as vibration mountings, impact absorbers, gaskets, seals, silencers, barriers and other equipment should be regularly inspected and maintained.

5.5 Using administrative controls

Administrative noise control measures reduce the amount of noise to which a person is exposed by reducing the time they are exposed to it. Examples include:

- organising schedules so that noisy work is done when only a few workers are present
- notifying workers and others in advance of noisy work so they can limit their exposure to it
- keeping workers out of noisy areas if their work does not require them to be there
- sign-posting noisy areas and restricting access
- providing quiet areas for rest breaks for workers exposed to noisy work
- limiting the time workers spend in noisy areas by moving them to quiet work before their daily noise exposure levels exceed the exposure standard.

If you rely on administrative controls, you should conduct regular checks to ensure that they are being complied with.

5.6 Using personal hearing protectors

Regulation 44: If personal protective equipment (PPE) is to be used at the workplace, the person conducting the business or undertaking must ensure that the equipment is:

- selected to minimise risk to health and safety
- suitable for the nature of the work and any hazard associated with the work
- a suitable size and fit and reasonably comfortable for the person wearing it
- maintained, repaired or replaced so it continues to minimise the risk
- used or worn by the worker, so far as is reasonably practicable.

Regulation 46: A worker must, so far as reasonably able, wear the PPE in accordance with any information, training or reasonable instruction.

Personal hearing protectors, such as ear-muffs or ear-plugs, should be used in the following circumstances:

- when the risks arising from exposure to noise cannot be eliminated or minimised by other more effective control measures,
- as an interim measure until other control measures are implemented
- where extra protection is needed above what has been achieved using other noise control measures.

If the use of personal hearing protectors is necessary, it is important that the hearing protectors are worn throughout the period of exposure to noise. Removing personal hearing protectors for even short periods significantly reduces the effective attenuation (noise reduction) and might provide inadequate protection. For example, a worker wearing a hearing protector for a full 8-hour day will receive the 30 dB maximum protection level. However, one hour without wearing the hearing protector causes the maximum protection level to fall to 9 dB.

Areas where people may be exposed to hazardous noise should be sign-posted as hearing protector areas and the boundaries of these areas should be clearly defined. Workers and other persons, including managers and visitors, should not enter these areas without wearing

appropriate personal hearing protectors, regardless of how short the time they stay in the hearing protector area.

Where sign-posting is not practicable, you should make other arrangements to ensure that workers and others know when personal hearing protectors are required. For example:

- attach prominent warning notices to tools and equipment indicating that personal hearing protectors should be worn when operating them
- provide written and verbal instructions on how to recognise circumstances in which personal hearing protectors are needed
- ensure effective supervision of identified hazardous tasks.

Personal hearing protectors should be selected and maintained in accordance with AS/NZS 1269.3 *Occupational noise management – hearing protector program*. Involve your workers in the selection process and offer a reasonable choice from a range of types.

Suppliers of hearing protectors should provide the full information on the attenuation likely to be provided including the SLC80 ratings, class and octave band attenuation values. The attenuation values should be derived from attenuation measurements made in accordance with AS/NZS 1270 *Acoustics – hearing protectors*.

Selection

When selecting personal hearing protectors you should consider:

- the degree of attenuation required in the worker's environment (see Table 4). Do not provide protectors that overprotect by cutting out too much sound – this can cause difficulties hearing verbal instructions and other sounds needed to work safely
- the suitability for the type of working environment and the work tasks. For example, ear-plugs are difficult to use hygienically for work that requires them to be inserted with dirty hands and in these circumstances, ear-muffs are more appropriate, but ear-muffs can be uncomfortable to wear in hot environments and can make it difficult for the wearer to enter a confined space or to wear a helmet
- the comfort, weight and clamping force of the personal hearing protector.

Measured exposure $L_{Aeq,8h}$ dB(A)	Class
Less than 90	1
90 to less than 95	2
95 to less than 100	3
100 to less than 105	4
105 to less than 110	5

Individual fit of personal hearing protectors is critical for optimum protection. Several devices are available to assist with this. Wearing work equipment—such as hard hats, dust masks and eye protection—may affect the performance of the protector. The fit of hearing protectors should be checked while the user is wearing regular work equipment. Workers wearing spectacles should be fitted with hearing protectors while wearing the spectacles.

Maintenance

Personal hearing protectors must be regularly inspected and maintained to ensure they remain in good, clean condition. The inspections should check that:

- ear-muff seals are undamaged
- the tension of headbands is not reduced
- there are no unofficial modifications
- compressible ear-plugs are soft, pliable and clean.

If disposable ear-plugs are used, they should only be worn once.

You must provide your workers with training, information and instruction in the proper use, fit, care and maintenance of personal hearing protectors. You should also:

- include the need to wear hearing protectors in your safety procedures
- place someone in charge of issuing and making sure replacements are readily available
- carry out spot checks to ensure that workers are wearing their hearing protectors when required and are using them correctly
- ensure all managers and supervisors set a good example and wear personal hearing protectors at all times when in hearing protector areas.

5.7 Audiometric testing

Regulation 58: A person conducting a business or undertaking must provide audiometric testing for a worker who is carrying out work for the business or undertaking if the worker is required to frequently use personal hearing protectors as a control measure for noise that exceeds the exposure standard.

Audiometric testing must be provided within three months of the worker commencing work. Starting the audiometric testing before people are exposed to hazardous noise (such as new starters or those changing jobs) provides a baseline as a reference for future audiometric test results. Regular follow-up tests must be carried out at least every two years. These should be undertaken well into the work shift so that any temporary hearing loss can be picked up.

More frequent audiometric testing (e.g. every six months) may be needed if exposures are at a high $L_{Aeq,8h}$, which is equal or greater than 100 dB(A).

Before introducing an audiometric testing program, you must consult with your workers and their health and safety representatives. It is important that your workers understand that the aim of the testing is to evaluate the effectiveness of control measures to protect their hearing.

Audiometric testing and assessment of audiograms should be carried out by competent persons in accordance with the procedures in AS/NZS 1269.4:2005 - *Occupational noise management - Auditory assessment*.

Workers should be given the results of audiometric testing accompanied by a written explanation of the meaning and implications. Only with the consent of the worker should you provide their results to other parties. Unidentifiable individual results and group data should be made available to health and safety representatives of the worker's work group.

The reasons for any changes in hearing levels over time should be thoroughly investigated. When temporary or permanent threshold shifts are revealed through audiometric assessments or a worker reports a recent diagnosis of tinnitus, you must review your control measures to

determine whether more effective control measures can be implemented so that your workers do not have to rely on personal hearing protectors.

If the worker is to continue using personal hearing protectors, you should:

- verify that the nominal performance of the worker's personal hearing protector is adequate for the level of exposure to noise
- examine the protector carefully and ensure it is not damaged
- check the protector fits the worker closely with no leakage paths for noise
- ask the worker if they have any difficulty using the protector
- check the worker uses the protector correctly and consistently whilst performing their work.

If workers are found to have sufficient hearing loss to interfere with the safe performance of their work, all reasonably practicable steps should be taken to modify the work environment. This may include providing:

- volume control on equipment such as telephones
- acoustically treated meeting areas with low noise and low sound reflections
- supplementary visual warning signals
- alternative work for the worker if other measures do not remedy the situation.

Monitoring hearing with regular audiometric testing is recommended in situations where workers are exposed to:

- any of the ototoxic substances listed in Appendix A where the airborne exposure (without regard to respiratory protection worn) is greater than 50 per cent of the national exposure standard for the substance, regardless of the noise level
- ototoxic substances at any level and noise with $L_{Aeq,8h}$ greater than 80 dB(A) or $L_{C,peak}$ greater than 135 dB(C)
- hand-arm vibration at any level and noise with $L_{Aeq,8h}$ greater than 80 dB(A) or $L_{C,peak}$ greater than 135 dB(C).

5.8 Information, training and instruction

Section 19: A person conducting a business or undertaking must ensure, so far as is reasonably practicable, that information, training and instruction is provided to workers and others at the workplace to protect them from health and safety risks.

Regulation 39: The information, training and instruction must, so far as is reasonably practicable, be provided in a way that can be easily understood by any person to whom it is provided.

Training should be provided to:

- those workers who may be exposed to hazardous noise or other agents that may contribute to hearing loss
- their managers and supervisors
- workplace health and safety committees and health and safety representatives
- those responsible for the purchase of plant, noise control equipment, personal hearing protectors and for the design, scheduling, organisation and layout of work.

The contents of the training program should include:

- the health and safety responsibilities of each party at the workplace
- how hearing can be affected by exposure to noise
- the detrimental effects hearing loss and tinnitus have on the quality of life, both at work and socially

- the tasks at the workplace that have the potential to give rise to hearing loss and the likely noise exposure level
- how to use noise control measures
- how to select, fit, wear, maintain and store personal hearing protectors
- how to report defects in hearing protectors and noise control equipment or raise any concerns regarding hazardous noise
- the purpose and nature of audiometric testing.

5.9 Implementing and maintaining control measures

A noise management plan may help implement the chosen noise control measures effectively. It should identify what action needs to be taken, who will be responsible for taking the action and by when.

The plan should be based on the results of any noise assessment and should also include:

- measuring noise levels to confirm that control measures are achieving expected attenuation
- specifications for purchasing or hiring plant
- a description of any training and supervision that may be needed
- control measures for temporary work areas and situations
- timeframes for reviewing noise assessments and control measures.

Regulation 37: You must ensure that the control measures you implement remain effective. This includes checking that the control measures are suitable for the nature and duration of the work, are installed, maintained and used correctly.

6. HOW TO REVIEW CONTROL MEASURES

Any noise control measures that are implemented must be reviewed, and if necessary revised, to make sure they work as planned and to maintain, so far as is reasonably practicable, a work environment that is without risks to health and safety.

Regulation 38: A person conducting a business or undertaking must review and as necessary revise noise control measures:

- when the control measure does not control the risk so far as is reasonably practicable
- before a change at the workplace that is likely to give rise to a new or different health and safety risk that the control measure may not effectively control
- if a new hazard or risk is identified
- if the results of consultation indicate that a review is necessary
- if a health and safety representative requests a review.

Control measures may be reviewed using the same methods as the initial hazard identification step.

Consult your workers and their health and safety representatives and consider the following:

- Are the control measures working effectively in both their design and operation?
- How accurate is the risk assessment process? Are all noisy activities being identified?
- Have new work methods or new plant made the work quieter?
- Has instruction and training provided to workers been successful?
- Have new requirements or information indicated that current controls are no longer the most effective?
- Is an alteration planned to any structure, plant or process that is likely to result in a worker being exposed to hazardous noise?
- Has an incident occurred as a result of a worker being exposed to hazardous noise?
- Have any audiometric tests revealed changes in hearing threshold levels?

You should decide on the time interval between noise assessments by consulting with your workers. Assessment should be repeated whenever there is:

- installation or removal of machinery or other noise sources likely to cause a significant change in noise levels
- a change in workload or equipment operating conditions likely to cause a significant change in noise levels or exposure times
- a change in building structure likely to affect noise levels
- a change to working arrangements affecting the length of time workers spend in noisy work areas.

If you design, manufacture or supply products used for work you should check that the product effectively eliminates or minimises exposure to noise by obtaining feedback from users. This can help in determining whether any improvements can be made.

7. ROLE OF DESIGNERS, MANUFACTURERS, SUPPLIERS AND INSTALLERS

Eliminating noise in the early stages of product planning (at the source) is more effective and usually cheaper than making changes after noise hazards are introduced into the workplace.

7.1 Designers

Designers of plant or structures used for work must ensure so far as is reasonably practicable that the plant or structure is designed to be without risks to the health and safety of persons.

Design of plant

Regulation 59: A designer of plant must design the plant so that its noise emission is as low as reasonably practicable.

Designers must provide information on the noise emission values of the plant (for example, data on sound power level or sound pressure level), the operating conditions of the plant when the noise emission is measured and the methods used to measure the noise emission. They must also provide information on any conditions required for safe use.

This information must be provided to manufacturers, importers and suppliers.

If you design plant you should consider:

- preventing or reducing the impact between machine parts
- replacing metal parts with quieter plastic parts
- combining machine guards with acoustic treatment
- enclosing particularly noisy machine parts
- selecting power transmission which permits the quietest speed regulation; for example, rotation-speed-controlled electric motors
- isolating vibration-related noise sources within machines.

You should also design:

- good seals for doors for machines
- machines with effective cooling flanges that reduce the need for air jet cooling
- quieter types of fans or placing mufflers in the ducts of ventilation systems
- quiet electric motors and transmissions
- pipelines for low flow speeds (maximum 5m/sec.)
- ventilation ducts with fan inlet mufflers and other mufflers to prevent noise transfer in the duct between noisy and quiet rooms.

Methods of maintenance and servicing should be taken into account in noise control design.

Design of buildings and structures

Designers of buildings and structures must take noise control into account from the beginning of the planning process and minimise the noise transmitted through the structure to the lowest level that is reasonably practicable.²

For new buildings designers should consider:

- the effect on noise levels of building reverberation, the building layout and location of workstations relative to any plant

² Guidance for designers of buildings on recommended background sound levels (i.e. noise coming from outside the room or from building services) for different types of workplaces can be found in *AS/NZS 2107:2000 Acoustics – Recommended design sound levels and reverberation times for building interiors*.

- selecting the frame, floor and machine bases so that all sources of disturbance can be provided with effective vibration isolation. Heavy, noisy equipment requires rigid, heavy bases. It is also possible to isolate machine bases from direct contact with the rest of the building frame (see Figure 2)
- isolating noise sources such as plant rooms
- designing acoustic treatments for noisy areas, for example, cover ceilings (and walls in the case of very high ceilings) with sound-absorbing material, use floating floors
- using flexible construction joints as building elements
- designing walls, floors, windows and doors to provide the necessary sound transmission loss
- covering floors of office areas with carpets.

Figure 2: The vibrations of an elevator drive are isolated from the building structure.

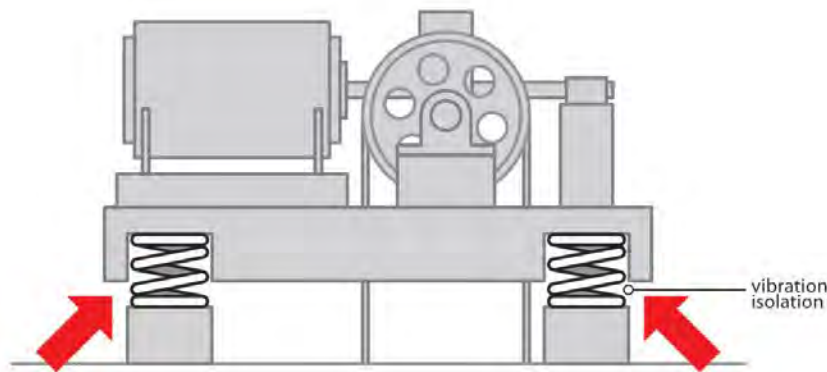

Sound insulating separate rooms

With automation of processes, remote control from a separate room may be possible. Some control measures may include:

- designing control rooms with materials having adequate transmission loss
- providing good sealing around doors and windows
- providing openings for ventilation with passages for cables and piping equipped with good seals.

Control rooms should be adequately ventilated with air-conditioning in hot working areas. Otherwise, there is a risk that the doors will be opened for ventilation, which would spoil the effectiveness of the room in reducing the noise level.

Figure 3: Examples of noise control measures in an industrial building

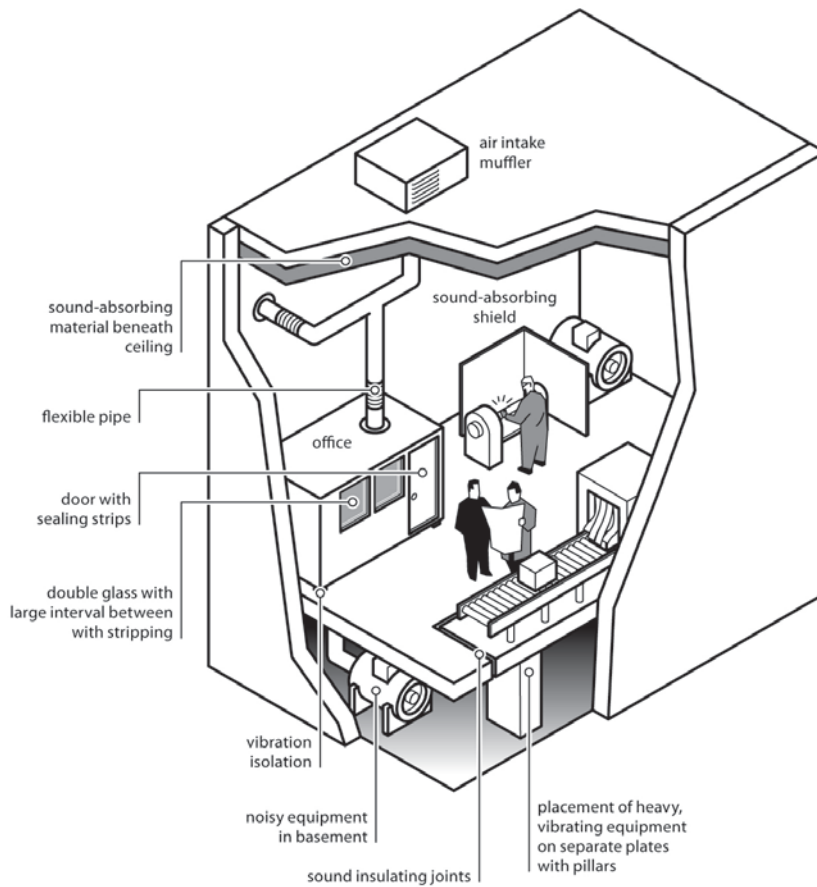

7.2 Manufacturers

Regulation 59: A manufacturer of plant must manufacture the plant so that its noise emission is as low as reasonably practicable.

Manufacturers of plant or structures used for work must ensure, so far as is reasonably practicable, that the plant or structure is manufactured without risks to the health and safety of persons. If noise cannot be eliminated, manufacturers must ensure the plant is manufactured so that its noise emission is as low as reasonably practicable and that the manufacturing process does not introduce new or additional noise hazards.

Manufacturers should manufacture plant:

- using and testing the safety measures specified by the designer
- using materials and techniques that minimise the risk of hearing loss by reducing noise to the lowest level reasonably practicable.

Manufacturers must provide information to an importer or supplier on the noise emission values of the plant, the operating conditions of the plant when the noise emission is measured and the methods used to measure the noise emission. They must also provide information on any conditions required for safe use.

7.3 Suppliers and importers

Suppliers or importers must ensure so far as is reasonably practicable that the plant is without risks to the health and safety of persons at the time of supply.

Suppliers and importers must take all reasonable steps to obtain the information that the manufacturer is required to provide on noise emission values and provide it to any person to whom the plant is supplied.

Suppliers and importers should:

- provide all noise control measures with the product as per the setup recorded on the noise test results
- provide maintenance information to ensure safe use and operation.

7.4 Installers

Installers must ensure so far as is reasonably practicable that the plant or structure is installed in such a way that it is without risks to the health and safety of persons. For example, installers should ensure that the installation is undertaken according to the designer's specifications. Isolating vibrating sources of noise may involve installing large heavy machines on separate bases or in such a way that they do not directly contact the remainder of the building structure.

Installers should also provide information to potential users about the conditions required for safe use, including maintenance requirements.

7.5 What information should be provided to potential users?

Designers, manufacturers, suppliers and importers must give purchasers and other potential users the information they need to safely use the plant, including the results of any calculations, analysis or testing carried out.

Information must include the noise emission values of the plant, the operating conditions of the plant when the noise emission is measured and the methods used to measure the noise emission. This information will help purchasers choose plant with low noise levels.

The testing information that should be supplied to the purchaser is listed in Table 5. Where relevant information on test procedures is contained in a test standard or a test report, reference to the standard or the report should be included. Information should be provided on peak noise levels, where relevant, as well as on continuous noise levels.

Where there is a selection of noise measurement results available, the preferred measurement is the sound pressure level at the operator's position.

Instructions for safe use should be communicated in a way that can be easily understood by users.

Table 5: Minimum noise testing information

Supplier's details	For example, name, local address, telephone and/or facsimile number , email
Manufacturer's details	For example, name, address, telephone and/or facsimile number ,email
Details of the plant tested	Including any noise controls, for example, make, model, serial number, relevant capacity/rating
Title or number of specific test standard or code followed	Including details of any departures from the standard. For example, if a machine needed to be mounted differently to the method given in the standard, the alternative mounting should be described
Details of operating conditions	If not specified in the standard, or if no specific test standard is available for the type of plant being tested. For example, test machine load, speed, type of material processed, details of installation and mounting of test machine, details of test environment, description of measurement instrumentation and procedure. Reference to a test report containing this information will suffice
Measurement position(s)	For example, operator's ear or 1 metre from machines
Index measured	For example, sound pressure level or sound power level
Frequency weighting	For example, A, C or linear
Time weighting	For example, slow, fast or peak, or Leq
Sound level or levels determined in testing.	
Units of measurement	For example, dB re: 20 micropascals
Details of tester	For example, name, address, telephone and/or facsimile number ,email, accreditation
Date issued	

APPENDIX A – OTHER CAUSES OF HEARING LOSS IN THE WORKPLACE

Vibration

Studies have indicated that there is a link between exposure to hand-arm vibration and hearing loss. Workers who use equipment such as chainsaws that subject the worker to both hand-arm vibrations and to noise may be more likely to suffer from hearing loss. Tools that may expose workers to both noise and hand-arm vibration include:

- pneumatic and electrical rotary tools such as concrete breakers, grinders, sanders and drills
- percussive tools such as chippers and riveters
- petrol-powered tools such as lawn-mowers, brush-cutters and chainsaws.

Control measures to reduce exposure to hand-arm vibration may involve finding alternative ways to do the work that eliminates the need to use vibrating equipment or to purchase tools that produce less vibration.

Ototoxic substances

Exposure to some chemicals can result in hearing loss. These chemicals are known as ototoxic substances. Hearing loss is more likely to occur if a worker is exposed to both noise and ototoxic substances than if exposure is just to noise or ototoxic substances alone.

There are three major classes of ototoxic substances: solvents, heavy metals and asphyxiants. Work activities that commonly combine noise and ototoxic substances include:

- painting
- printing
- boat building
- construction
- furniture making
- fuelling vehicles and aircraft
- manufacturing, particularly of metal, leather and petroleum products
- degreasing
- fire-fighting
- weapons firing

Some medications have also been identified as ototoxic substances. These include some anti-cancer, anti-inflammatory, anti-thrombotic, anti-malarial, anti-rheumatic and antibiotic drugs. Quinine and salicylic acids (such as aspirin) are also considered to be ototoxic substances.

Table A1 below lists those ototoxic substances most commonly used in workplaces. Some of these can be absorbed through the skin and are considered particularly hazardous.

Exposure standards for chemicals and noise have not yet been altered to take account of increased risk to hearing. Until revised standards are established, it is recommended that the daily noise exposure of workers exposed to any of the substances listed in Table A1 be reduced to 80 dB(A) or below. They should also undergo audiometric testing and be given information on ototoxic substances.

Control measures such as substitution, isolation and local ventilation should be implemented to eliminate or reduce chemical exposures. Personal protective equipment should be used to prevent skin and respiratory absorption when other controls are insufficient.

Table A1: Some common ototoxic substances³

Type	Name	Skin Absorption
Solvents	Butanol	√
	Carbon disulphide	√
	Ethanol	
	Ethyl benzene	
	n-heptane	
	n-hexane	
	Perchloroethylene	
	Solvent mixtures and fuels Stoddard solvent (white spirits)	√
	Styrene	
	Toluene	√
	Trichloroethylene	√
	Xylenes	
Metals	Arsenic	
	Lead	
	Manganese	
	Mercury	√
	Organic tin	√
Others	Acrylonitrile	√
	Carbon monoxide	
	Hydrogen cyanide	√
	Organophosphates	√
	Paraquat	

Acoustic Shock

Acoustic incidents are sudden, unexpected loud noises occurring during telephone headset use, including crackles, hisses, whistles, shrieks or high-pitched noises. Acoustic shock is not caused by the loudness of a telephone, as all phone noise is electronically limited to a peak noise level of 123 decibels, but by a sudden rise in noise levels.

³ Morata T.C. (2007) Promoting hearing health and the combined risk of noise-induced hearing loss and ototoxicity, *Audiological Medicine*, Vol.5, Issue 1, pp33-40.

The noises can come from a wide variety of sources, either within the transmission system or from the customer end. Sources of acoustic incidents include those outlined in Table A2:

Table A2: Sources of acoustic incidents	
Sources within the transmission system	Sources from the customer end
<ul style="list-style-type: none"> ▪ faulty or damaged networks, telephones and headset equipment ▪ broadband and narrowband interference ▪ mobile phones or fax machines used in call centres 	<ul style="list-style-type: none"> ▪ feedback oscillation from some cordless phones ▪ alarm signals ▪ phone receivers slammed down or dropped ▪ tones from misdirected facsimiles and modems ▪ noises made close to the receiver (eg. whistling)

Although acoustic incidents occur in workplaces (mainly call centres), only a very small proportion cause the symptoms known as ‘acoustic shock’ in workers.

High background noise levels at the workplace can increase the risk of acoustic shock occurring from an acoustic incident. For example, operators may raise the volume in their headsets to improve hearing thereby increasing the impact of any sudden, loud telephone noise. When an acoustic incident occurs, the operator’s automatic reaction may be to remove the headset or receiver as quickly as possible and, in some cases, this may help prevent or reduce the effects of acoustic shock.

Other factors, such as a middle ear inflammation and feelings of tension, may increase the likelihood of an acoustic shock resulting from an acoustic incident.

Acoustic shock symptoms

The effect on individuals can vary greatly for the same increase in sound level. Only a small number of people develop symptoms from an acoustic incident. Why a person experiences symptoms after an acoustic incident is not known with certainty and is still being researched.

Some researchers believe that a combination of stress and sudden loud noise causes excessive contraction of the middle ear muscles, triggering the acoustic shock symptoms.

Audiologists have grouped symptoms into three categories:

- Primary (immediate) symptoms, which include but are not limited to:
 - a feeling of fullness in the ear
 - burning sensations or sharp pain around or in the ear
 - numbness, tingling or soreness down the side of face, neck or shoulder
 - nausea or vomiting
 - dizziness
 - tinnitus and other head noises such as eardrum fluttering.
- Secondary symptoms, which include but are not limited to:
 - headaches
 - fatigue
 - a feeling of being off-balance
 - anxiety
- Tertiary symptoms, which include but are not limited to:
 - hypersensitivity (sensitivity to previously tolerated sounds such as loud voices, television and radio)
 - hyper vigilance i.e. being overly alert.

People experiencing such symptoms will respond in different ways. As with other workplace injuries and ill health, some may experience further effects, including anger, anxiety, social isolation and other psychological problems.

Few people suffer hearing loss from acoustic shock. To assist in the diagnosis where this may occur, consideration should be given to baseline audiometric testing of all operators' hearing by a specialist when they commence work to establish their baseline hearing ability.

Control measures

Control measures to eliminate or minimise the risk of acoustic shock include:

- providing high quality headsets with acoustic shock protection devices
- giving prompt attention to damaged equipment and network faults – the equipment or network supplier or an acoustic specialist should be contacted if necessary
- ensuring the proper fitting, use and maintenance of headsets
- reducing background noise in the room
- providing information and training on how to detect warning sounds for example, cordless phones being used too close to the base station at the customer end. Training on warning sounds should also prepare operators to know when to remove headsets as quickly as possible, where necessary
- with hotdesking work, ensuring workers turn the headset volume down as soon as possible after a changeover
- considering work organisation issues, such as unreasonable or unrealistic performance pressures or demands, which may cause tension and distress
- preventing mobile phones from being used in call centres.

Control of background noise in call centres

Possible control measures to implement include:

- reviewing the design and layout of the room and workstations:
 - reducing external and building service noise
 - reducing reverberation within the room by using sound absorbing materials
 - placing acoustic barriers around/between workstations and other call centre areas
- encouraging people to not talk loudly or hold discussions near operators
- locating fax machines, photocopiers and printers away from operators
- controlling radio noise and use of mobile telephones
- with hotdesking, ensuring changeovers are smoothly managed and quiet
- providing sufficient room for workers to move around at changeover times without crowding.

Managing acoustic incidents

After an acoustic incident, the worker should:

- remove the headset immediately
- in some circumstances, move to the 'break out' area
- report the incident and any symptoms to the supervisor
- discuss with the supervisor their ability to continue work and, where appropriate, relocate to another workstation.

After an acoustic incident, you should:

- ensure the event is recorded and logged
- discuss the incident and ability to continue work with the worker
- where symptoms are persistent or severe, refer the worker to a general practitioner and/or an audiologist for assessment and treatment of possible injury
- enquire into the cause of the noise, including whether it is from an internal or external source

- ensure the headset and other equipment is checked for clarity of sound and possible damage and faults
- remove damaged or faulty equipment from service
- review the adequacy of the noise control measures and general working environment.

APPENDIX B – NOISE HAZARD IDENTIFICATION CHECKLIST

Description of work location: _____

Activities at workstation: _____

Assessed by: _____

Date: _____

'Yes' to any of the following indicates the need to carry out a noise assessment if exposure to the noise cannot be immediately controlled.

Hazard identification questions	Yes	No
1. Is a raised voice needed to communicate with someone about one metre away?	<input type="checkbox"/>	<input type="checkbox"/>
2. Do your workers notice a reduction in hearing over the course of the day? (This may only become noticeable after work, for example, needing to turn up the radio on the way home)	<input type="checkbox"/>	<input type="checkbox"/>
3. Are your workers using noisy powered tools or machinery?	<input type="checkbox"/>	<input type="checkbox"/>
4. Are there noises due to impacts (such as hammering, pneumatic impact tools) or explosive sources (such as explosive powered tools, detonators)?	<input type="checkbox"/>	<input type="checkbox"/>
5. Are personal hearing protectors used for some work?	<input type="checkbox"/>	<input type="checkbox"/>
6. Do your workers complain that there is too much noise or that they can't clearly hear instructions or warning signals?	<input type="checkbox"/>	<input type="checkbox"/>
7. Do your workers experience ringing in the ears or a noise sounding different in each ear?	<input type="checkbox"/>	<input type="checkbox"/>
8. Do any long-term workers appear to be hard of hearing?	<input type="checkbox"/>	<input type="checkbox"/>
9. Have there been any workers' compensation claims for noise-induced hearing loss?	<input type="checkbox"/>	<input type="checkbox"/>
10. Does any equipment have manufacturer's information (including labels) indicating noise levels equal or greater than any of the following: (a) 80 dB(A) $L_{Aeq,T}$ (T= time period over which noise is measured)? (b) 130 dB(C) peak noise level? (c) 88 dB(A) sound power level?	<input type="checkbox"/> <input type="checkbox"/> <input type="checkbox"/>	<input type="checkbox"/> <input type="checkbox"/> <input type="checkbox"/>
11. Do the results of audiometry tests indicate that past or present workers have hearing loss?	<input type="checkbox"/>	<input type="checkbox"/>
13. Are any workers exposed to noise and ototoxins in the workplace?	<input type="checkbox"/>	<input type="checkbox"/>
14. Are any workers exposed to noise and hand-arm vibration?	<input type="checkbox"/>	<input type="checkbox"/>

APPENDIX C – READY RECKONER

Tables C1 to C3 provide a simple way of working out a worker's $L_{Aeq,8h}$ (eight-hour equivalent continuous sound pressure level) if you know the noise level and duration of each of the noisy tasks carried out by the worker during the work shift.⁴

From Tables C1 or C2 you read off the number of “noise exposure points” that correspond to a particular task's noise level and exposure duration. Table C1 is for noise levels between 75 and 105 dB(A) and Table C2 is for higher noise levels between 95 and 125 dB(A).

For example, a task producing a noise level at the worker's ear of 93 dB(A) that is done for two lots of 30 minutes in a shift (i.e. one hour total) produces 80 noise exposure points. Another task with a noise level of 120 dB(A) for one minute during the shift produces 670 points.

These points can be added (in the normal arithmetic way) to give the total exposure points for the shift. Table C3 is then used to convert the total points to the $L_{Aeq,8h}$.

In the example above, if these were the only noisy tasks carried out by the worker, the points total is 750 and (from Table C3, rounding to the nearest whole decibel) the $L_{Aeq,8h}$ for the worker is 94 dB(A).

This calculated $L_{Aeq,8h}$ value can be compared with the exposure standard for noise i.e. $L_{Aeq,8h} = 85$ dB(A). Additionally, noise exposure points can be used to prioritise the noise control program by showing which tasks make the greatest contribution to the total noise exposure.

In the example above the worker's $L_{Aeq,8h}$ is greater than the standard, so noise control action is needed. Although it only lasts for one minute, the 120 dB(A) task contributes more than eight times as much as the other task to the total exposure and so should be the first one tackled.

In this scheme the exposure standard for noise – $L_{Aeq,8h} = 85$ dB(A) – is 100 points.

⁴ Based on Health and Safety Executive UK guidance material with the points used in the tables derived from procedures in AS/NZS1269.1

Table C1: Exposure points for 75-105 dB(A)/15minutes – 12 hours

Sound Level L _{Aeq,T} dB(A)	Duration of exposure per shift							
	15 min	30 min	1 h	2 h	4 h	8 h	10 h*	12 h*
105	320	640	1270	2530	5060	10120	12650	15180
104	250	500	1000	2010	4020	8040	10050	12060
103	200	400	800	1600	3200	6400	8000	9600
102	160	320	640	1270	2540	5070	6340	7600
101	130	250	500	1010	2010	4030	5040	6040
100	100	200	400	800	1600	3200	4000	4800
99	80	160	320	640	1270	2540	3180	3810
98	63	130	250	500	1010	2020	2520	3030
97	50	100	200	400	800	1600	2000	2410
96	40	80	160	320	640	1270	1590	1910
95	32	63	130	250	510	1010	1260	1520
94	25	50	100	200	400	800	1000	1210
93	20	40	80	160	320	640	800	960
92	16	32	63	130	250	510	630	760
91	13	25	50	100	200	400	500	600
90	10	20	40	80	160	320	400	480
89	7.9	16	32	64	130	250	320	380
88	6.3	13	25	50	100	200	250	300
87	5.0	10	20	40	80	160	200	240
86	4.0	8.0	16	32	64	130	160	190
85	3.2	6.3	13	25	50	100	130	150
84	2.5	5.0	10	20	40	80	100	120
83	2.0	4.0	8.0	16	32	64	80	96
82	1.6	3.2	6.3	13	25	51	63	76
81	1.3	2.5	5.0	10	20	40	50	60
80	1.0	2.0	4.0	8.0	16	32	40	48
79	0.8	1.6	3.2	6.4	13	25	32	38
78	0.6	1.3	2.5	5.0	10	20	25	30
77	0.5	1.0	2.0	4.0	8.0	16	20	24
76	0.4	0.8	1.6	3.2	6.4	13	16	19
75	0.3	0.6	1.3	2.5	5.1	10	13	15

Table C2: Exposure points for 95-125 dB(A)/5 seconds – 10 minutes

Sound Level L _{Aeq,T} dB(A)	Duration of exposure per shift							
	5 sec	10 sec	15 sec	30 sec	1 min	2 min	5 min	10 min
125	180	360	530	1050	2110	4220	10540	21080
124	140	280	420	840	1680	3350	8370	16750
123	110	220	330	670	1330	2660	6650	13300
122	90	180	260	530	1060	2110	5280	10570
121	70	140	210	420	840	1680	4200	8390
120	56	110	170	330	670	1330	3330	6670
119	44	88	130	270	530	1060	2650	5300
118	35	70	110	210	420	840	2100	4210
117	28	56	84	170	330	670	1670	3340
116	22	44	66	130	270	530	1330	2650
115	18	35	53	110	210	420	1050	2110
114	14	28	42	84	170	330	840	1680
113	11	22	33	67	130	270	670	1330
112	8.8	18	26	53	110	210	530	1060
111	7.0	14	21	42	84	170	420	840
110	5.6	11	17	33	67	130	330	670
109	4.4	8.8	13	26	53	110	270	530
108	3.5	7.0	11	21	42	84	210	420
107	2.8	5.6	8.4	17	33	67	170	330
106	2.2	4.4	6.6	13	27	53	130	270
105	1.8	3.5	5.3	11	21	42	110	210
104	1.4	2.8	4.2	8.4	17	33	84	170
103	1.1	2.2	3.3	6.7	13	27	67	130
102	0.9	1.8	2.6	5.3	11	21	53	110
101	0.7	1.4	2.1	4.2	8.4	17	42	84
100	0.6	1.1	1.7	3.3	6.7	13	33	67
99	0.5	0.9	1.3	2.7	5.3	11	27	53
98	0.4	0.7	1.1	2.1	4.2	8.4	21	42
97	0.3	0.6	0.8	1.7	3.3	6.7	17	33
96	0.2	0.5	0.7	1.3	2.7	5.3	13	27
95	0.2	0.4	0.5	1.1	2.1	4.2	11	21

Table C3: Conversion	
Total exposure points	L _{Aeq,8h} dB(A)
32000	110
25420	109
20190	108
16040	107
12740	106
10120	105
8040	104
6400	103
5070	102
4030	101
3200	100
2540	99
2020	98
1600	97
1270	96
1010	95
800	94
640	93
510	92
400	91
320	90
250	89
200	88
160	87
130	86
100	85
80	84
64	83
51	82
40	81
32	80
25	79
20	78
16	77
13	76
10	75

Notes:

1. If there is only one source of noise exposure, a quick glance at the background colour of the table cell corresponding to the sound level and duration of exposure will tell you if the worker is:
 - (a) above the L_{Aeq,8h} 85 dB(A) exposure standard - **Red**
 - (b) well below the L_{Aeq,8h} 85 dB(A) standard - **Green**
 - (c) marginal (between L_{Aeq,8h} 80 and 85 dB(A)) – **Yellow**
2. For durations of exposure not listed in the table, add together the points from two durations that together give the same duration. For example, for five hours at 95 dB(A), add together the points for four hours at 95 dB(A) and one hour at 95 dB(A), i.e. 510 + 130, giving a total of 640 points.
3. The tables can be extended to include both higher and lower sound levels. A change of 10 dB(A) results in a tenfold change in the points. For example, one hour exposure at 108 dB(A) will give 10 times the points for one hour at 98 dB(A), that is, 2500 points.
4. For shift lengths of 10 hours or more (*), the adjustments listed in Table 3 should be added to the L_{Aeq,8h} before comparing the result with the exposure standard for noise.

Example: Carpenter working a 10.5-hour shift using tools and machines listed below.

Machine/Process	Measured Sound Level $L_{Aeq,T}$ dB(A)	Duration per shift
Circular Saw – cutting hardwood	94	2 h
Planer – planing hardwood	100	3 h
Power Drill – drilling hardwood	87	4 h
Hammering nails into wood	98	10 min
Background	70	1 h 20 min

If you want to just quickly see if the carpenter is exposed above the $L_{Aeq,8h} = 85$ dB(A) noise standard, look up points for 94 dB(A) and 2 h in Table C1. You will see that the cell is red, so you know without going any further that the carpenter is exposed to noise above the standard.

If you want to actually work out the carpenter’s 8h-equivalent continuous noise level, $L_{Aeq,8h}$, then use Tables C1, C2 and C3 as below:

Machine/Process	Sound Level $L_{Aeq,T}$ dB(A)	Duration per shift	Points
Circular Saw – cutting hardwood	94	2 h	200
Planer – planing hardwood	100	3 h	2 h 800 1 h 400
Power Drill – drilling hardwood	87	4 h	80
Hammering nails into wood	98	10 min	42
Background	70	1 h 20 min	1 h 0.4 20 m 0.1
		Total 10.5 h	Total 1522.5

From Table C3: $L_{Aeq,8h} = 97$ dB(A), but as the shift is 10.5 hours, an adjustment of +1 dB(A) is needed, hence the adjusted $L_{Aeq,8h} = 98$ dB(A).

APPENDIX D – CONTENTS OF A NOISE ASSESSMENT REPORT

Checklist: What should be included in a noise assessment report?	If present
When	
Date of Assessment	<input type="checkbox"/>
Who	
Name of Assessor	<input type="checkbox"/>
Information (background/qualifications) of assessor	<input type="checkbox"/>
Equipment used	
Type of equipment used to take measurements	<input type="checkbox"/>
Calibration details for equipment	<input type="checkbox"/>
How the noise measurements were taken	
Where measurements were taken (general area or operator ear position)	<input type="checkbox"/>
Period of time over which the measurements were taken	<input type="checkbox"/>
What was assessed	
The area, plant, process, activity and workers that were assessed	<input type="checkbox"/>
Source of noise	
The sources (plant/process/jobs) of the noise	<input type="checkbox"/>
Whether all the noise sources that may be operating at the time were taken into account	<input type="checkbox"/>
Whether there were any significant noise sources that were not operating during the assessment	<input type="checkbox"/>
Systems of work	
Brief description of the work activity (how it's done; plant/process/activity/operating conditions/duration of process etc)	<input type="checkbox"/>
Hours of workshift (eg 8-hour or 12-hour shift)	<input type="checkbox"/>
Whether assessment is for a normal/typical day or for a worst case scenario	<input type="checkbox"/>
Results	
The results of measurements in terms of levels and durations	<input type="checkbox"/>
Interpretation of the results, (i.e. compared to exposure standards; what do the results mean etc.; ranking of noise sources)	<input type="checkbox"/>
Action Required	
Any obvious noise controls that could be implemented, or the need for more detailed noise control study	<input type="checkbox"/>
Other relevant factors	
Information on and adequacy of any control measures already in place and hearing protectors used during the assessment	<input type="checkbox"/>
Where relevant, information about the environment (types of walls, surfaces, buildings, operational state of machinery, etc.)	<input type="checkbox"/>

APPENDIX E – ENGINEERING CONTROL MEASURES

The following are 10 simple noise control techniques that have wide application across industry. In many cases they will produce substantial noise reductions quickly and cheaply, with little or no effect on normal operation or use of plant.⁵

1. DAMPING

Typical applications - Chutes, hoppers, machine guards, panels, conveyors, tanks

Technique

There are 2 basic techniques:-

- unconstrained layer damping where a layer of bitumastic (or similar) high damping material is stuck to the surface
- constrained layer damping where a laminate is constructed

Constrained layer damping is more rugged and generally more effective. Either re-manufacture guards, panels or other components from commercially available sound deadened steel or buy self-adhesive steel sheet. The latter can simply be stuck on to existing components (inside or outside) covering about 80% of the flat surface area to give a 5 - 25 dB reduction in the noise radiated (use a thickness that is 40 per cent to 100 per cent of the thickness of the panel to be treated).

Limitations: the efficiency falls off for thicker sheets. Above about 3mm sheet thickness it becomes increasingly difficult to achieve a substantial noise reduction.

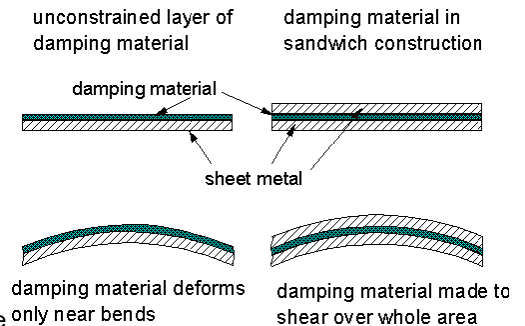

2. FAN INSTALLATIONS

Typical applications - Axial flow or centrifugal fans.

Technique

Maximum fan efficiency coincides with minimum noise. Any fan installation feature that tends to reduce fan efficiency is therefore likely to increase noise. Two of the most common examples are bends close to the fan (intake side in particular) and dampers close to the fan intake or exhaust.

Ideally, for maximum fan efficiency and minimum noise, make sure there is at least 2 - 3 duct diameters of straight duct between any feature that may disturb the flow and the fan itself.

Noise reductions of 3 -12 dB are often possible.

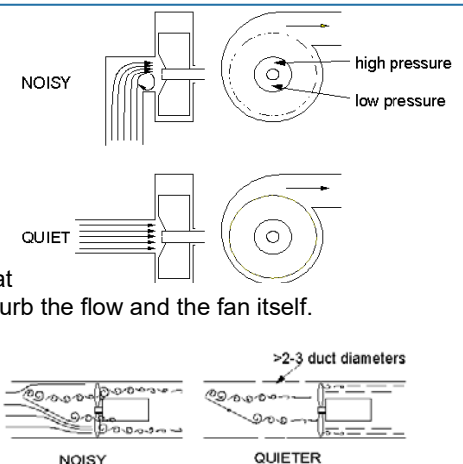

3. DUCTWORK

Typical applications - Extraction, ventilation, cooling, openings in walls and enclosures.

Technique

Instead of fitting silencers, it is often possible to achieve a 10 - 20 dB reduction in airborne noise from a duct or opening by lining the last bend in the ductwork with acoustic absorbent (foam or rockwool / fibreglass). Alternatively, construct a simple absorbent lined right-angled bend to fit on the opening. Ideally, either side of the bend should be lined along a length equivalent to twice the duct diameter. Where flow velocities are high (> 3m/s), consider using cloth faced absorbent. Duct vibration can usually be treated by damping (as above).

⁵ Source Health and Safety Executive UK

4. FAN SPEED

Typical applications - Axial or centrifugal flow fans.

Technique

Fan noise is roughly proportional to the 5th power of fan speed. So in many cases it is possible to achieve a large noise reduction from a small drop in fan speed by changing control systems or pulley sizes and re-setting dampers. The following table provides a guide to the trade-off that can be expected.

FAN SPEED REDUCTION	NOISE REDUCTION
10%	2 dB
20%	5 dB
30%	8 dB
40%	11 dB
50%	15 dB

5. PNEUMATIC EXHAUSTS

Technique

Almost invariably it is possible to reduce pneumatic exhaust noise permanently by 10 - 30 dB by fitting effective silencers. The following are the practical points that can make the difference between success and failure:-

- *back pressure* : fit a larger coupling and silencer
- *clogging* : fit a straight-through silencer that cannot clog (and has no back pressure)
- *multiple exhausts* : manifold them into a single, larger diameter pipe fitted with the rear silencer from virtually any make of car (from your local tyre and exhaust fitter). Typically 25 dB reduction.

Note : a well designed silencer will not increase system back pressure.

6. PNEUMATIC NOZZLES

Typical applications - Cooling, drying, blowing

Technique

In most cases, it is possible to replace existing nozzles (usually simple copper pipe outlets) for quiet, high efficiency units. These not only reduce noise levels by up to 10 dB, but also use less compressed air. The types of nozzle to look out for are entraining units (schematic at right) from various manufacturers and in a variety of sizes.

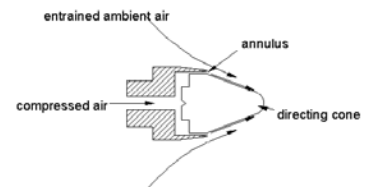

7. VIBRATION ISOLATION PADS

Typical applications - Machine feet, pumps, mezzanine installations

Technique

Mounting motors, pumps, gearboxes and other items of plant on rubber bonded cork (or similar) pads can be a very effective way of reducing transmission of vibration and therefore noise radiated by the rest of the structure. This is particularly the case where vibrating units are bolted to steel supports or floors. However, a common error with the use of these pads is for the bolt to "short-circuit" the pad, resulting in no isolation. Additional pads should be fitted under the bolt heads as shown.

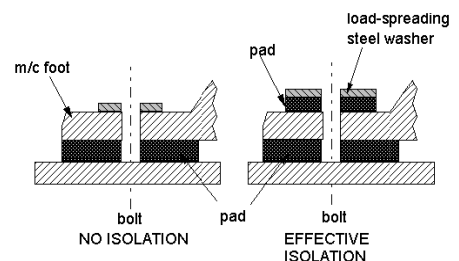

There are many types of off-the-shelf anti-vibration mounts available, for instance rubber/neoprene or spring types. The type of isolator that is most appropriate will depend on, among other factors, the mass of the plant and the frequency of vibration to be isolated. Any supplier of anti-vibration mounts will be able to advise you on this.

8. EXISTING MACHINE GUARDS

Technique

The existing guards on many machines can often be improved to provide a significant noise reduction. The two principles involved, which must be used in combination, are:-

(i) *Minimise gaps*

Reducing by half the "gap" open area in a set of guards can reduce the noise by 3 dB. If you can reduce the openings (flexible seals, additional close fitting panels etc) by 90 per cent, then a 10 dB noise reduction is possible.

(ii) *Acoustic absorbent*

Lining a significant proportion of the inside of the guards with acoustic absorbent (foam, rockwool / fibreglass) will reduce the noise "trapped" by the guards.

Consequently, less noise will escape through any gaps. Failure to line the inside of the guards could result in an increase in noise at the operator's position if the gaps have been minimised as in (i) above.

In most cases, both sets of modifications can be tested in mock-up form using cardboard (and wide tape) to extend the guarding and temporarily fitting areas of acoustic foam inside. Not only does this process help with the practical aspects (access, visibility etc), but it usually also provides a very good indication of the noise reduction that can be expected. Guard vibration radiated as noise can also be treated via damping (as above).

9. CHAIN & TIMING BELT DRIVES

Technique

Noisy chain drives can often be replaced directly with quieter timing belts. Within the range of timing belts available, there are also quiet designs that use different tooth profiles to minimise noise. There is also a new design of belt for applications where noise is critical which uses a chevron tooth pattern to provide very quiet running. Noise reductions in the range of 6 - 20 dB are often possible using this approach.

10. ELECTRIC MOTORS

Technique

Most companies have large numbers of electric motors used on anything from fans to pumps to machine tools. However, it is not very common knowledge that general duty motors are available (at little or no cost premium) that are up to 10 dB(A) or more quieter than typical units as direct replacements. The best approach is to feed these motors into the system over a period of time so that all replacement motors are quiet motors.



Workplace Standards

PO Box 56 Rosny Park TAS 7018

Helpline 1300 366 322 (within Tasmania)
(03) 6233 7657 (outside Tasmania)

Fax: (03) 6233 8338

www.worksafe.tas.gov.au